

SUSPENSION SYSTEMS

making everyday smoother

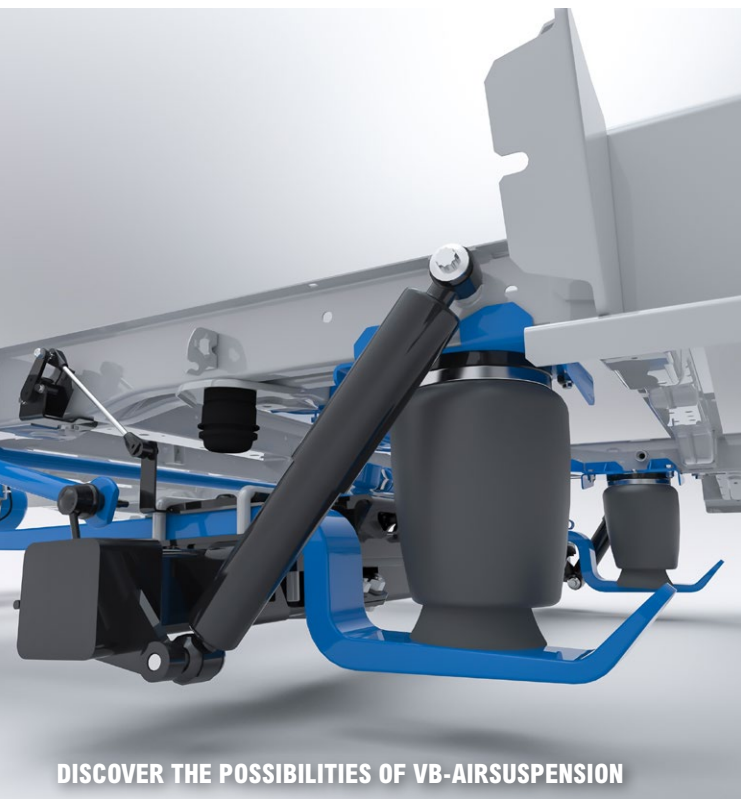

airsuspension



DISCOVER THE POSSIBILITIES OF VB-AIRSUSPENSION

BETTER SAFETY AND COMFORT ON THE ROAD.

VB-FullAir

Full air suspension

OUR VB-FULLAIR SYSTEMS PROVIDE GREATER COMFORT, INCREASED STABILITY, OPTIMUM DRIVEABILITY AND USEFUL FUNCTIONALITIES.



THE BEST SOLUTION FOR SUSPENSION PROBLEMS.

VB-FullAir: full air suspension with extensive control options

Full air suspension is an automatic, adjustable solution for various (suspension) problems and/or requirements that replaces the existing leaf, coil spring or torsion bar suspension with a full air suspension system. This system includes air springs, shock absorbers, height sensors, a compressor and an electronic control unit (VB-ASCU) and, depending on the make and model of vehicle, is available for both the front and rear axle.

VB-FULLAIR SUSPENSION SYSTEMS FROM VB-AIRSUSPENSION COME WITH A REMOTE CONTROL THAT CAN BE USED TO OPERATE VARIOUS FUNCTIONS OF THE SUSPENSION SYSTEM WITH EASE.

The air suspension system filters out unevenness in the road surface, improving ride comfort. While driving, the vehicle will constantly remain at the ride height set by VB-Airsuspension during installation. The standard ride height is determined during the development of the air suspension and is fixed.

The ride height is the ideal height for comfort and stability. The driveability and stability of the vehicle are improved, which in turn increases safety. The access/loading platform height can be raised and lowered when the vehicle is at a standstill (in some cases with the handbrake on), allowing for easy vehicle entry/exit and for loading/unloading goods.

	Increases ride height	Minimises sagging	Reduces vehicle roll	Improves suspension comfort
VB-FULLAIR Full air suspension	++	+++	++	++
	Improves driving characteristics	Increases safety	Improves stability	Control options
	++	+	+	++



A VB-FULLAIR SYSTEM IS OFTEN FITTED TO MEET THE FOLLOWING REQUIREMENTS:

- INCREASE RIDE HEIGHT
- REDUCE SAGGING
- REDUCE VEHICLE ROLL
- IMPROVE SUSPENSION COMFORT
- IMPROVE DRIVING CHARACTERISTICS
- INCREASE SAFETY
- IMPROVE STABILITY
- CONTROL OPTIONS (E.G. VEHICLE CAN BE RAISED/LOWERED)



DISCOVER THE VARIOUS FULL AIR SUSPENSION SYSTEMS.

Our full air suspension systems can be divided into three different categories:

VB-FullAir 2C rear axle:

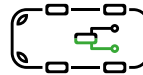

VB-FullAir 2C front axle:

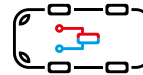

VB-FullAir 3C:

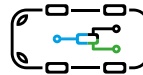

VB-FullAir 4C:

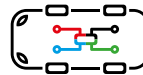



BENEFITS OF VB-FULLAIR:

- Control options
- Constant ride height
- Greater comfort
- Optimum driveability
- Increased stability
- Comfortable ride for passengers
- Improved protection for fragile goods
- Less wear on tyres/brakes

ADJUSTING THE HEIGHT OF THE VEHICLE IS SIMPLE.



VB-FULLAIR 2C – STANDARD

	Memory function – stored height is activated.	< 0 km/h
	Manual control to vary the loading/unloading height.	< 0 km/h

The height of the air suspension can only be set when the vehicle is at a standstill (for loading and unloading).



VB-FULLAIR 2C – MOTORHOME

	Ferry – the front is lowered to the minimum level, for example to make it easy for the vehicle to drive onto a ferry.	< 30 km/h
	Cargo space – the front axle is automatically raised to the maximum level to make it easy to load and unload the vehicle at the rear.	< 0 km/h
	Manual control to vary the loading/unloading height.	< 0 km/h

The Ferry function lets you temporarily adjust the ride height at a maximum speed of 30 kilometres an hour. The other functions can only be operated when the vehicle is at a standstill.



VB-FullAir 2C: on the front axle

VB-FullAir 2C is a full air suspension system on the front axle of the vehicle. 2C or 2-Corner indicates that two height sensors are fitted. VB-FullAir 2C for the front axle is only available for certain makes and types.

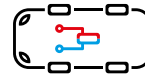

The VB-FullAir 2C system on the front axle is supplied with one of the remote controls shown opposite. You can use the remote control to easily control various functions of the system.

SET CONTENTS: COIL SPRING SUSPENSION

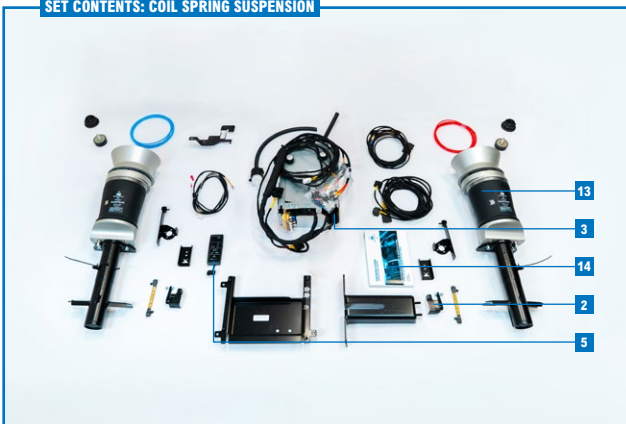

VB-FULLAIR 2C SYSTEMS CONTENTS:

COIL SPRING SUSPENSION

VB-FULLAIR 2C SYSTEMS CONTENTS:		COIL SPRING SUSPENSION
2	Height sensors	+
3	VB-ASCU (control unit)	+
5	Remote control	+
13	McPherson front struts with air springs	+
14	User manual	+
+	Shock absorbers (in most cases)	+
+	Fasteners	+
+	Fitting instructions	+
+	Approval documentation (TÜV/ABE)	+

ADJUSTING THE HEIGHT OF THE VEHICLE IS SIMPLE.

VB-FullAir 2C on the rear axle

VB-FullAir 2C is a full air suspension system on the rear axle of the vehicle.

2-Corner indicates that two height sensors have been fitted.

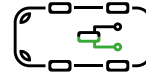

The VB-FullAir 2C system on the rear axle is supplied with one of the remote controls shown opposite. You can use the remote control to easily control various functions of the system.

VB-FULLAIR 2C – STANDARD

	Memory function – stored height is activated.	< 0 km/h
	Manual control to vary the loading/unloading height.	< 0 km/h

The height of the air suspension can only be set when the vehicle is at a standstill (for loading and unloading).



VB-FULLAIR 2C – MOTORHOME

	Ferry – the rear is raised to the maximum level, for example to make the vehicle easy to drive onto a ferry.	< 30 km/h
	Cargo space – the rear axle is lowered to the minimum level to make it easy to load and unload the vehicle at the rear.	< 0 km/h
	Manual control to vary the loading/unloading height.	< 0 km/h



The Ferry function lets you temporarily adjust the ride height at a maximum speed of 30 kilometres an hour. The other functions can only be operated when the vehicle is at a standstill.



VB-FULLAIR 2C SYSTEMS CONTENTS:

		LEAF SUSPENSION	COIL SPRING SUSPENSION	TORSION BAR SUSPENSION
1	Air springs	+	+	+
2	Height sensors	+	+	+
3	VB-ASCU – control unit	+	+	+
4	Main springs	+		
5	Remote control	+	+	+
6	Shock absorbers – in most cases	+	+	+
7	Compressor	+	+	+
8	Air tank	+	+	+
9	Suspension arms			+
10	Torsion bars			+
11	Air spring support brackets			+
14	User manual	+	+	+
+	Fasteners	+	+	+
+	Fitting instructions	+	+	+
+	Approval documentation (TÜV/ABE)	+	+	+

SET CONTENTS: LEAF SUSPENSION

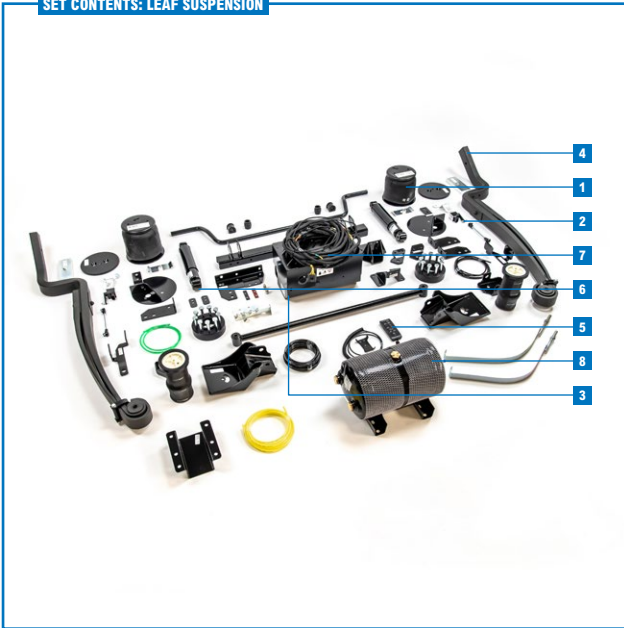

SET CONTENTS: COIL SPRING SUSPENSION

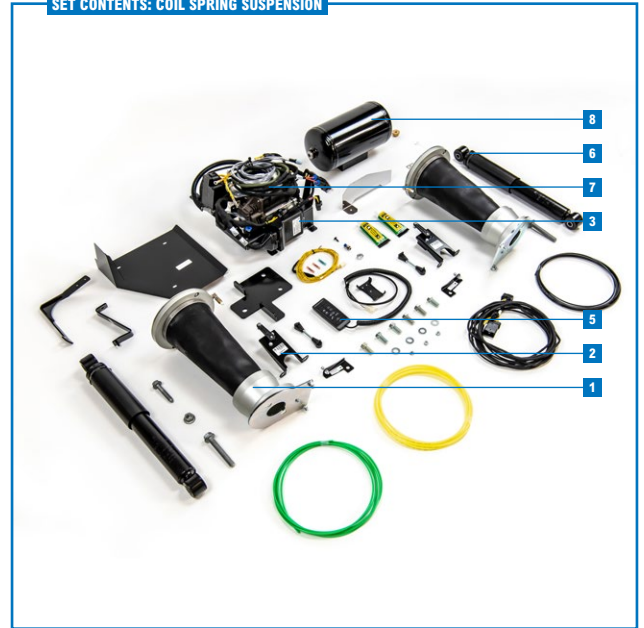

REMOTE: STANDARD – 1052200022





REMOTE: MOTORHOME – 1052200034

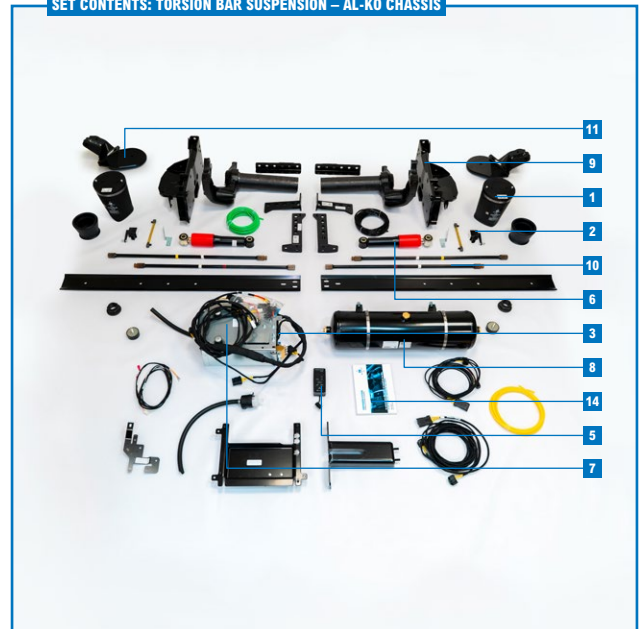

SET CONTENTS: TORSION BAR SUSPENSION – AL-KO CHASSIS



VB-FULLAIR 3C – MOTORHOME

	Off Road – increase of around 30 mm for greater ground clearance on rough terrain.	< 30 km/h
	Parking – lower the vehicle to virtually the maximum level to make it easier to get in and out. You can also use this function (depending on the original vehicle height) to reduce the ride height in order to enter a car park with a low roof or to drive under a gateway.	< 30 km/h
	Manual control to vary the loading/unloading height.	< 0 km/h
	Ferry – the rear is raised to the maximum level, for example to make the vehicle easy to drive onto a ferry.	< 30 km/h
	Cargo space – the front axle is automatically raised and the rear is lowered to the maximum level to make it easy to load and unload the vehicle at the rear.	< 0 km/h

The Ferry function lets you temporarily adjust the ride height at a maximum speed of 30 kilometres an hour. The other functions can only be operated when the vehicle is at a standstill.

SET CONTENTS: LEAF SUSPENSION

FRONT AND REAR ALWAYS AT RIDE HEIGHT.

VB-FullAir 3C

VB-FullAir 3C is a full air suspension system on the rear axle and an auxiliary air suspension system on the front axle of the vehicle. 3-Corner indicates that three sensors are fitted: two rear height sensors and one front pressure sensor.

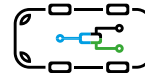





The VB-FullAir 3C system is only available for a limited number of motorhomes with an Iveco Daily chassis. The VB-FullAir 3C system is supplied with the remote control shown opposite. You can use the remote control to easily control various functions of the system.

VB-FULLAIR 3C* SYSTEMS CONTENT:

VB-FULLAIR 3C* SYSTEMS CONTENT:		LEAF SUSPENSION
1	Air springs	+
2	Height sensors	+
3	VB-ASCU – control unit	+
4	Main springs	+
5	Remote control	+
6	Shock absorbers – in most cases	+
7	Compressor	+
8	Air tank	+
12	Pressure sensor	+
+	Fasteners	+
+	Fitting instructions	+
+	User manual	+
+	Approval documentation (TÜV/ABE)	+

* Consists of an auxiliary air suspension system on the front axle and a VB-FullAir 2C system on the rear axle.

VB-FULLAIR 4C – FULL OPTION

	Memory function – stored height is activated.	< 0 km/h
	Manual control to vary the loading/unloading height.	< 0 km/h
	Ferry – the rear is raised to the maximum level, for example to make the vehicle easy to drive onto a ferry.	< 30 km/h
	Water discharge – tilts the vehicle to the side with the water discharge to allow the wastewater tank and the toilet tank to be fully emptied.	< 0 km/h
	Cargo space – the front axle is automatically raised and the rear is lowered to the maximum level to make it easy to load and unload the vehicle at the rear.	< 0 km/h



The Off Road and Car Park functions let you temporarily adjust the ride height at a maximum speed of 30 kilometres an hour. The Sport function works at all speeds. The other functions can only be operated when the vehicle is at a standstill.

VB-FULLAIR 4C – MOTORHOME

	AutoLevel – includes a digital levelling function that can be used to set your vehicle level (as far as the spring travel permits).	< 30 km/h
	Sport – lower the level of the vehicle by around 30 mm for better handling and firm chassis adjustment.	< 0 km/h
	Off Road – increase of around 30 mm for greater ground clearance on rough terrain.	< 30 km/h
	Car Park / Parking – lower the vehicle almost to its maximum level to make it easier to get in and out. You can also use this function (depending on the original vehicle height) to reduce the ride height in order to enter a car park with a low roof or to drive under a gateway.	< 30 km/h

The Ferry, Off Road and Parking functions let you temporarily adjust the ride height at a maximum speed of 30 kilometres an hour. The other functions can only be operated when the vehicle is at a standstill.

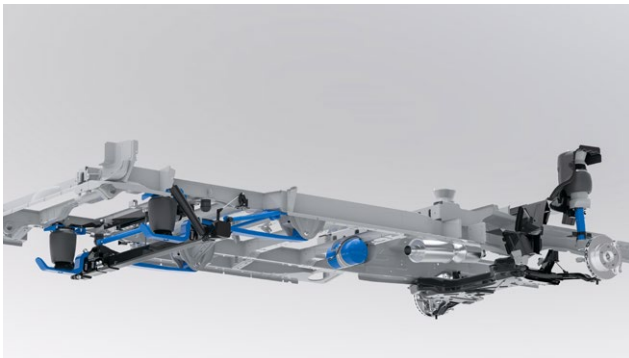

EXTENSIVE CONTROL OPTIONS.

VB-FullAir 4C

VB-FullAir 4C is a full air suspension system on the front and rear axle of the vehicle. 4-Corner indicates that four height sensors are fitted: two on the front axle and two on the rear axle.

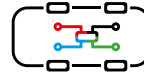

The VB-FullAir 4C system is supplied with one of the remote controls shown on the left page. You can use the remote control to easily control all functions of the system.

VB-FULLAIR 4C SYSTEMS CONTENT:

		LEAF SUSPENSION	COIL SPRING SUSPENSION	TORSION BAR SUSPENSION
1	Air springs	+	+	+
2	Height sensors	+	+	+
3	VB-ASCU – control unit	+	+	+
4	Main springs	+		
5	Remote control	+	+	+
6	Shock absorbers – in most cases	+	+	+
7	Compressor	+	+	+
8	Air tank	+	+	+
9	Suspension arms			+
10	Torsion bars			+
11	Air spring support brackets			+
13	McPherson front struts with air springs	+	+	+
14	User manual	+	+	+
+	Fasteners	+	+	+
+	Fitting instructions	+	+	+
+	Approval documentation (TÜV/ABE)	+	+	+

SET CONTENTS: LEAF SUSPENSION

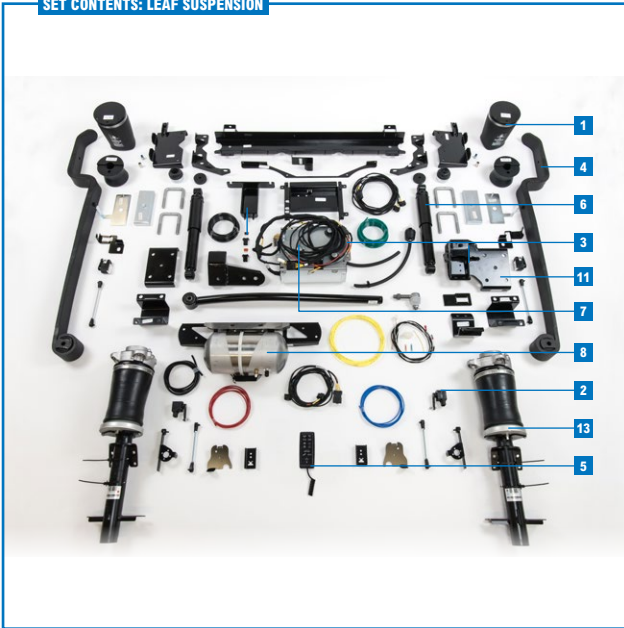

SET CONTENTS: COIL SPRING SUSPENSION

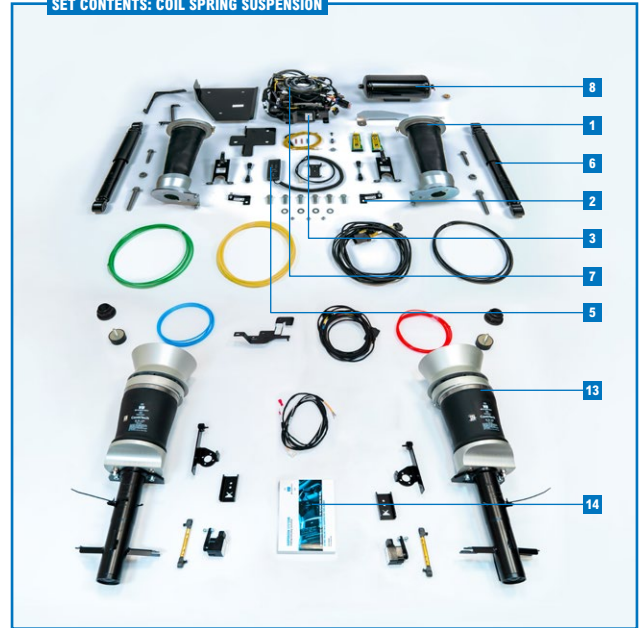

REMOTE: FULL OPTION – 1052200023



REMOTE: MOTORHOME – 1052200036



SET CONTENTS: TORSION BAR SUSPENSION – AL-KO CHASSIS

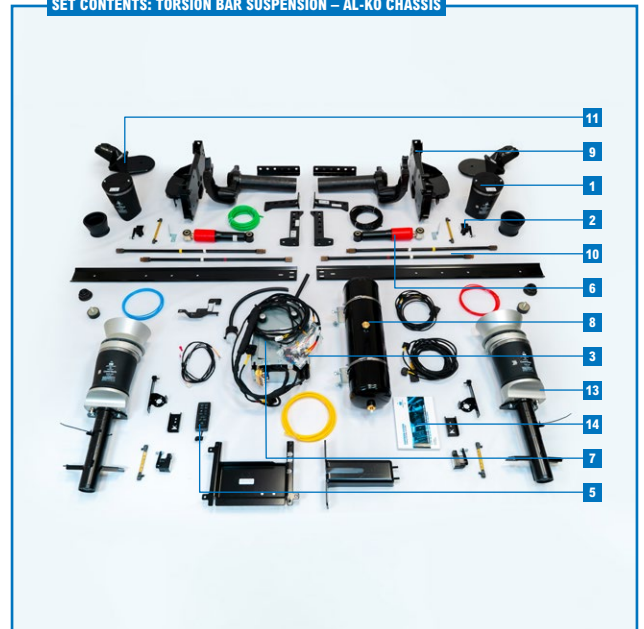

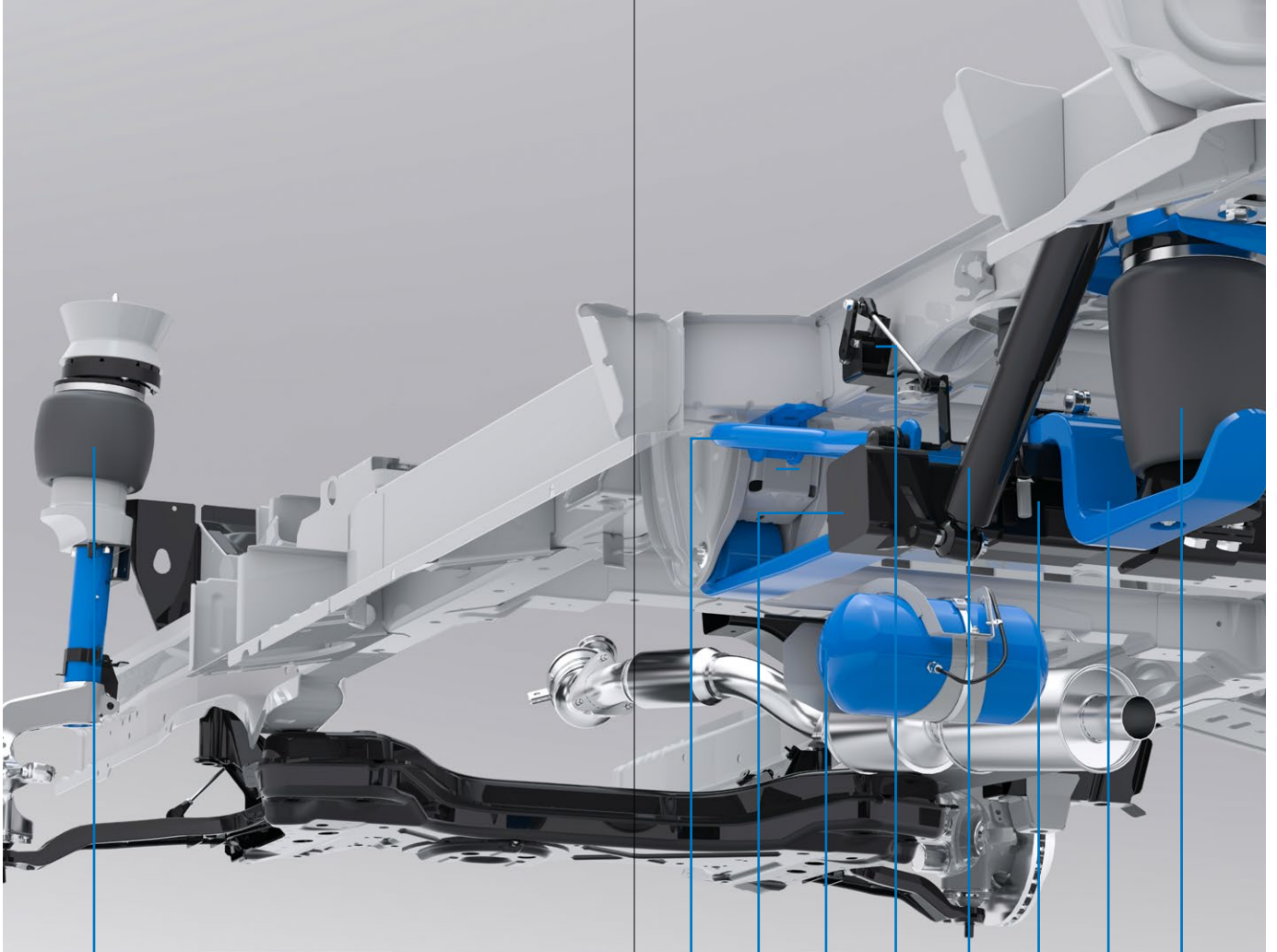

13

10

7

8

2

6

3

4

1



**FULL AIR SUSPENSION
SYSTEMS EFFECTIVELY
FILTER UNEVENNESS FROM
THE ROAD SURFACE.**



OPTIONS: ALWAYS CONTINUE TO OPERATE THE AIR SUSPENSION.

The full air suspension systems from VB-Airsuspension can also be expanded with a number of options. The following options are available for:

- VB-FullAir 2C
- VB-FullAir 3C
- VB-FullAir 4C

Emergency valve kit

The VB-FullAir system can be pressurised by means of filling valves in the event of a possible electronic fault or a defect in the compressor. The vehicle can be brought up to ride height again by means of an external air supply so that the journey can be continued.

'Extra time' module

This module in VB-ASCU ensures that the air suspension remains active for one hour after the ignition is switched off. The vehicle's ignition can therefore be switched off, while all the functions of the air suspension remain active.

Additional switch

This is an additional switch that allows the high/low function of the air suspension to be controlled from a different location in the vehicle, for example at the rear door. The advantage of this is that the driver does not have to walk to the cab to operate the air suspension.

Software version

A modified software version can be selected depending on the application and use of the vehicle.



OPTION: FAST AND SMOOTH LEVELLING.

An additional option for our VB-FullAir 4C systems is VB-AutoLevel.

VB-AutoLevel

This module allows the vehicle to be positioned horizontally, even when the vehicle is standing on uneven ground. At the push of a button, the vehicle can be levelled quickly and smoothly. Unevenness of more than 10 cm can be corrected (depending on the type of vehicle). Only suitable for VB-FullAir 4C systems.



Our products fall into one of four product groups. These product groups contain a variety of systems for many different makes and models, meaning that there is always a suitable solution for you.



FULL AIR SUSPENSION



SEMI AIR SUSPENSION



HELPER AND REINFORCED SPRINGS

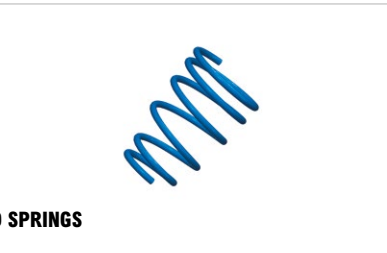

SPECIAL COMPONENTS

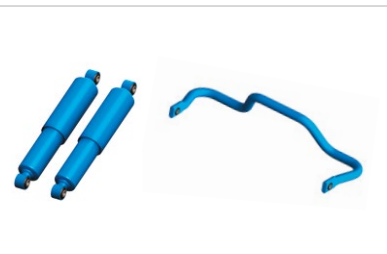

THE IDEAL SOLUTION.

Product Finder

Is extensive expertise a requirement when looking for a suitable solution for your vehicle? *Certainly not.* Our website's Product Finder is the perfect tool to help you find the best solution for your vehicle. Simply enter some basic data about the vehicle in question and set out your specific issues and/or preferences to determine the most suitable vehicle solution. If the list of issues and/or requirements in our Product Finder seems overly extensive, that is because we offer just the right solutions for many issues and requirements.

VB-Wizard

Does this make it hard for you to know which issue or requirement to focus on in order to determine the most suitable solution for your vehicle? *We understand.* If that is the case, we recommend using our VB-Wizard. On our website, you will find the VB-Wizard at the bottom right in our Product Finder. This feature goes through the most common issues and/or requirements with you step by step, with detailed descriptions (and animations) to make everything recognisable.

HEAD TO OUR WEBSITE AT WWW.VBAIRSUSPENSION.COM AND SEE FOR YOURSELF JUST HOW EASY IT IS TO USE OUR PRODUCT FINDER AND THE VB WIZARD.

Once you have established a top three of suitable VB products for your vehicle, simply request your quote from one of our local VB Partners. If you have any further questions, our VB-Partners will be happy to help you!

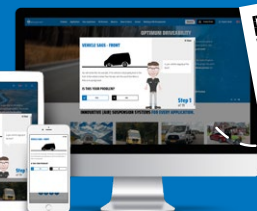

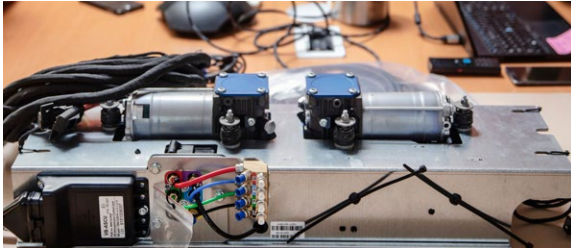
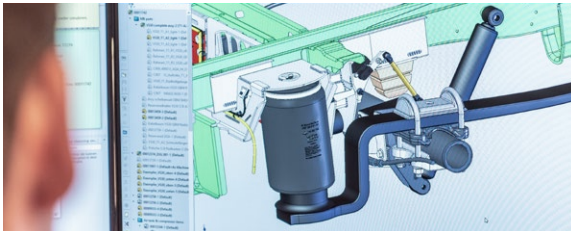

WE MAKE EVERY JOURNEY
A GOOD ONE.



VB-AIRSUSPENSION IS ACTIVE WORLDWIDE.

As a leading company experiencing rapid growth, we want all our customers across the globe to benefit from our premium suspension applications. These suspension applications provide improved comfort, better driving characteristics and improved safety, in turn making every day smoother.

MAKING EVERYDAY SMOOTHER.

According to this motto, we aim to provide our customers with the best possible service – and we've been very successful so far! After all, our highly motivated team has been developing and building suspension applications and various air suspension systems for light commercial vehicles, ambulances, car transporters, motorhomes, 4x4 vehicles and off-road vehicles for more than 30 years. Our product portfolio ranges from reinforced springs to full air suspension solutions with active shock absorbers for front and rear axles. We are especially proud of our official recognition from big names such as Mercedes-Benz, Volkswagen, Ford, Renault, PSA and AL-KO – the highest recognition that an accessory specialist can receive from a vehicle manufacturer. TÜV approvals and 'Letters Of No Objection' (LONO) from various vehicle manufacturers mean that our products are also available for other vehicles.

- MORE THAN 30 YEARS OF EXPERIENCE
- 195 EMPLOYEES
- 9 SUBSIDIARIES WORLDWIDE
- REPRESENTED BY PARTNERS IN 42 COUNTRIES
- DELIVERY TO MORE THAN 60 COUNTRIES
- MORE THAN 355 ACCREDITED INSTALLATION PARTNERS
- MORE THAN 885 TRAINED SPECIALISTS
- MORE THAN 300,000 AIR SUSPENSION SYSTEMS SOLD

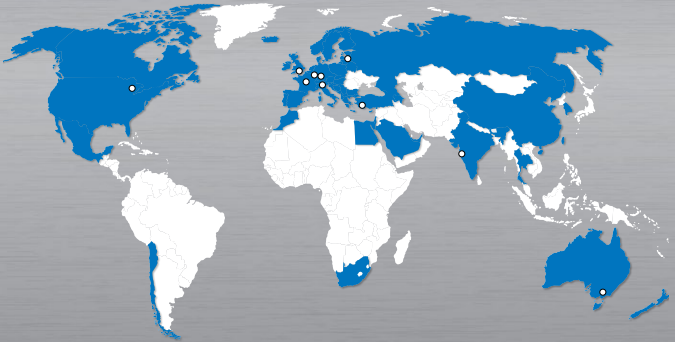

DISCOVER OUR PRODUCTS.

Our products find their way to satisfied users through an extensive network of international partners and dealers. Our partners and dealers are authorised specialists that have received extensive training in the installation of our products and in the provision of a high-quality service and appropriate advice.

To find your nearest partner or dealer, visit www.vbairsuspension.com.