

SUSPENSION SYSTEMS

making everyday smoother

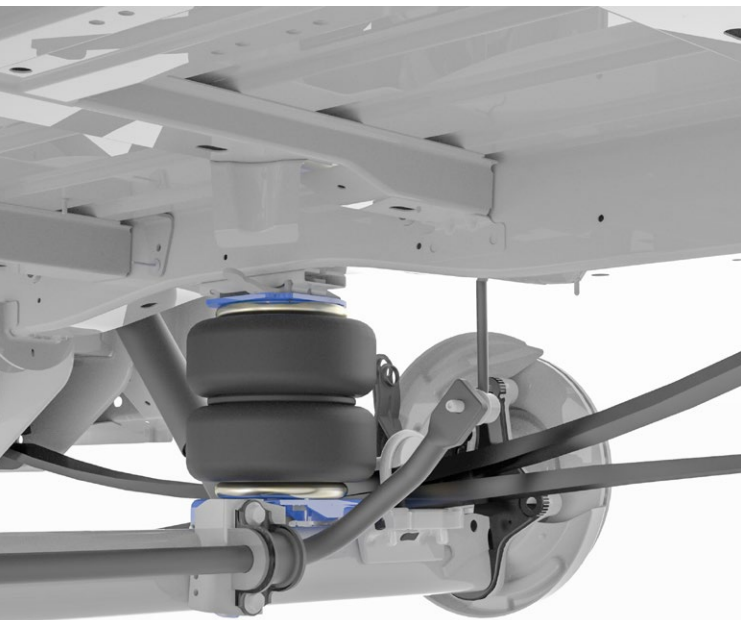

airsuspension



DISCOVER THE POSSIBILITIES OF VB-AIRSUSPENSION

BETTER SAFETY AND COMFORT ON THE ROAD.

VB-SemiAir

Semi air suspension



CREATE MORE SPRING TRAVEL WITH SEMI AIR SUSPENSION.

VB-SemiAir: semi air suspension

With semi air suspension, the suspension is adjustable within specific limits. VB-SemiAir is available for both vehicles with leaf springs and vehicles with torsion bar suspension. On a vehicle with leaf springs, an air spring is fitted between the chassis and the rear axle. On a vehicle with torsion bar suspension, the air spring is mounted on the side of the chassis. Both VB-SemiAir systems support the existing suspension.

WORRY LESS ABOUT YOUR LOAD.

VB-SemiAir is supplied as a 'two-chamber system'. This means the air springs are not connected to each other. Using a two-chamber system allows left and right to be adjusted separately, enabling levelling of the vehicle – within certain limits – even when loaded unevenly.

	Increases ride height	Minimises sagging	Reduces vehicle roll	Improves suspension comfort
VB-SEMIAIR Semi air suspension	++	++	+	++
	Improves driving characteristics	Automatic adjustment		
	+			



VB-LEVELAIR IS OFTEN FITTED TO MEET THE FOLLOWING REQUIREMENTS:

- INCREASED RIDE HEIGHT
- REDUCED SAGGING
- REDUCED VEHICLE ROLL
- IMPROVED SUSPENSION COMFORT
- IMPROVED DRIVING CHARACTERISTICS



DISCOVER THE VARIOUS SEMI AIR SUSPENSION SYSTEMS.

Different semi air suspension products are available, depending on the vehicle make and model.

- VB-SemiAir basic system
 - *Inflation valves*
- VB-SemiAir comfort system
 - *Control panel*
 - *Digital control unit*
- VB-LevelAir*
 - *Automatic level control*

BENEFITS OF VB-SEMIAIR:

- INCREASED RIDE HEIGHT AND GREATER SPRING TRAVEL
- IMPROVED STABILITY
- REDUCED OFF-CENTRE LEVEL
- VARIABLE SPRING FORCE
- COST-CONSCIOUS CHOICE
- 'PLUG-AND-PLAY' SYSTEM ALLOWS FOR QUICK INSTALLATION
- THE BODY, EQUIPMENT AND LOAD REMAIN PROTECTED AGAINST VIBRATION/IMPACT
- HEAVY LOADS ARE NO LONGER NOTICEABLE FROM THE OUTSIDE
- LESS STRAIN ON SHOCK ABSORBERS

* See our product-specific brochure for more information about our VB-LevelAir air suspension system.

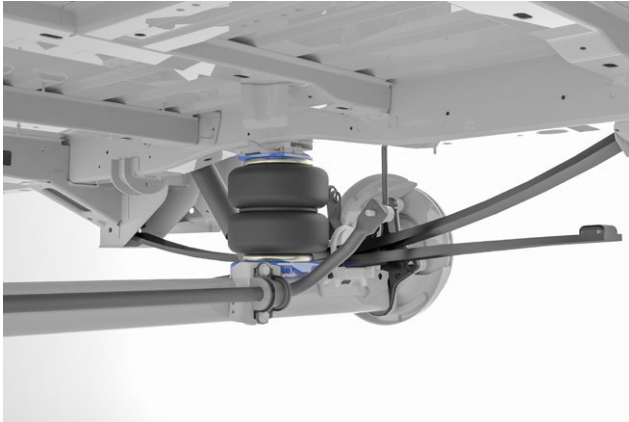

SET CONTENTS: LEAF SUSPENSION

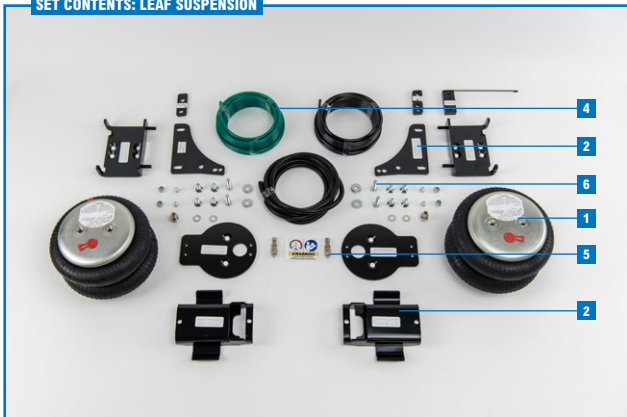

SET CONTENTS: TORSION BAR SUSPENSION



SETTING THE SUSPENSION WITHIN CERTAIN LIMITS.

VB-SemiAir basic system

With the VB-SemiAir basic system, the spring force can be varied within specific limits. This makes the VB-SemiAir basic system a good option for vehicles that are always heavily loaded and occasionally carry variable loads, as the pressure can stay more or less the same. You will need to pressurise the VB-SemiAir basic system yourself using an external air supply, e.g. a tyre inflator.

- On a vehicle with leaf springs, an air spring is fitted between the chassis and the rear axle. The air spring supports the existing leaf spring.
- On a vehicle with torsion bar suspension, the air spring is mounted on the side of the chassis. The air spring supports the existing torsion bar suspension.

CONTENTS OF BASIC SYSTEMS:

		LEAF SUSPENSION	TORSION BAR SUSPENSION
1	Air springs	+	+
2	Air spring support brackets	+	+
3	Shock absorbers		+
4	Air tubes	+	+
5	Inflation valves	+	+
6	Fasteners	+	+
+	Fitting instructions	+	+
+	User manual	+	+
+	Approval documentation (TÜV/ABE)	+	+



SET CONTENTS: LEAF SUSPENSION

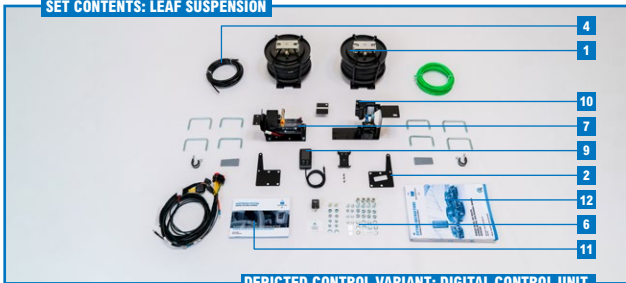

DEPICTED CONTROL VARIANT: DIGITAL CONTROL UNIT

SET CONTENTS: TORSION BAR SUSPENSION



DEPICTED CONTROL VARIANT: CONTROL PANEL

CHANGING LOADS, CONSISTENT VEHICLE BEHAVIOUR.

VB-SemiAir comfort system

With the VB-SemiAir comfort system, the spring force can be adjusted (manually) within specific limits. This makes the VB-SemiAir comfort system a good option for vehicles that are often heavily loaded and regularly carry variable loads.

- On a vehicle with leaf springs, an air spring is fitted between the chassis and the rear axle. The air spring supports the existing leaf spring.
- On a vehicle with torsion bar suspension, the air spring is mounted on the side of the chassis. The air spring supports the existing torsion bar suspension.

CONTENTS OF COMFORT SYSTEMS:

CONTENTS OF COMFORT SYSTEMS:		LEAF SUSPENSION	TORSION BAR SUSPENSION
1	Air springs	+	+
2	Air spring support brackets	+	+
3	Shock absorbers		+
4	Air tubes	+	+
6	Fasteners	+	+
7	Compressor	+	+
8	Control panel with pressure gauges and high/low switch	+	+
9	Digital control unit with display for various setting options	+	
10	VB-SACU*	+	+
11	User manual	+	+
12	Fitting instructions	+	+
+	Approval documentation (TÜV/ABE)	+	+

* The VB-SemiAir comfort system with digital control unit has a VB-SACU electronic control unit.

THE VB-SEMIAIR COMFORT SYSTEM IS AVAILABLE WITH DIFFERENT CONTROL VARIANTS

CONTROL PANEL – LCV – DRIVER'S SEAT



CONTROL PANEL – MOTORHOME – DASHBOARD



DIGITAL CONTROL UNIT



The VB-SemiAir comfort system with digital control unit offers a number of additional benefits. For example, you can specify the unit used to display the air pressure or review (historic) notifications. This way you have access to more information about your auxiliary air suspension system.

SIMPLE MANUAL OPERATION OF SEMI AIR SUSPENSION.

VB-SemiAir comfort system with control panel

The VB-SemiAir comfort system consists of a VB-SemiAir basic system including a control panel with two pressure gauges, two high/low switches and a powerful heavy-duty compressor. The high/low switches make it easy to change your vehicle's ride height. You can easily inflate the air springs, as the pressure gauges give an accurate reading of the pressure (in bar) in the springs.

VB-SemiAir comfort system with digital control unit*

The VB-SemiAir comfort system consists of a VB-SemiAir basic system including a digital control unit and a compressor box with valve block, an electronic control unit (VB-ASCU) and a heavy-duty compressor. The digital control unit can be used to operate both air springs separately. The unit shows the bellows pressure for each air spring, and you can use the up and down arrows to increase or decrease the pressure in the air springs per spring or for both at once. Another benefit is that you can choose where you want to hang or place the digital control unit in the vehicle, within certain limits. This means there is no loss of useful storage compartments and no need to route (air) lines through the vehicle.

* The VB-SemiAir comfort system with digital control unit is not yet available for all vehicles at the time of writing. Contact your VB-Partner for more information.

In addition to the products from the 'full air suspension' product group, we also offer a wide range of other products. Our products fall into one of four product groups. These product groups contain a variety of systems for many different makes and models, meaning that there is always a suitable solution for you.



FULL AIR SUSPENSION



SEMI AIR SUSPENSION



HELPER AND REINFORCED SPRINGS



SPECIAL COMPONENTS

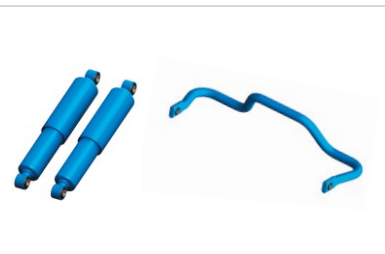

THE IDEAL SOLUTION.

Product Finder

Is extensive expertise a requirement when looking for a suitable solution for your vehicle? *Certainly not.* Our website's Product Finder is the perfect tool to help you find the best solution for your vehicle. Simply enter some basic data about the vehicle in question and set out your specific issues and/or preferences to determine the most suitable vehicle solution. If the list of issues and/or requirements in our Product Finder seems overly extensive, that is because we offer just the right solutions for many issues and requirements.

VB-Wizard

Does this make it hard for you to know which issue or requirement to focus on in order to determine the most suitable solution for your vehicle? *We understand.* If that is the case, we recommend using our VB-Wizard. On our website, you will find the VB-Wizard at the bottom right in our Product Finder. This feature goes through the most common issues and/or requirements with you step by step, with detailed descriptions (and animations) to make everything recognisable.

HEAD TO OUR WEBSITE AT WWW.VBAIRSUSPENSION.COM AND SEE FOR YOURSELF JUST HOW EASY IT IS TO USE OUR PRODUCT FINDER AND THE VB WIZARD.

Once you have established a top three of suitable VB products for your vehicle, simply request your quote from one of our local VB Partners. If you have any further questions, our VB-Partners will be happy to help you!



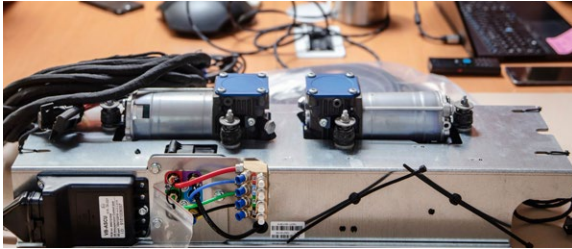
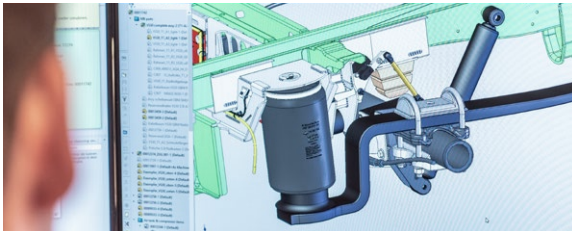

WE MAKE EVERY JOURNEY
A GOOD ONE.



VB-AIRSUSPENSION IS ACTIVE WORLDWIDE.

As a leading company experiencing rapid growth, we want all our customers across the globe to benefit from our premium suspension applications. These suspension applications provide improved comfort, better driving characteristics and improved safety, in turn making every day smoother.

MAKING EVERYDAY SMOOTHER.

According to this motto, we aim to provide our customers with the best possible service – and we've been very successful so far! After all, our highly motivated team has been developing and building suspension applications and various air suspension systems for light commercial vehicles, ambulances, car transporters, motorhomes, 4x4 vehicles and off-road vehicles for more than 30 years. Our product portfolio ranges from reinforced springs to full air suspension solutions with active shock absorbers for front and rear axles. We are especially proud of our official recognition from big names such as Mercedes-Benz, Volkswagen, Ford, Renault, PSA and AL-KO – the highest recognition that an accessory specialist can receive from a vehicle manufacturer. TÜV approvals and 'Letters Of No Objection' (LONO) from various vehicle manufacturers mean that our products are also available for other vehicles.

- MORE THAN 30 YEARS OF EXPERIENCE
- 195 EMPLOYEES
- 9 SUBSIDIARIES WORLDWIDE
- REPRESENTED BY PARTNERS IN 42 COUNTRIES
- DELIVERY TO MORE THAN 60 COUNTRIES
- MORE THAN 355 ACCREDITED INSTALLATION PARTNERS
- MORE THAN 885 TRAINED SPECIALISTS
- MORE THAN 300,000 AIR SUSPENSION SYSTEMS SOLD

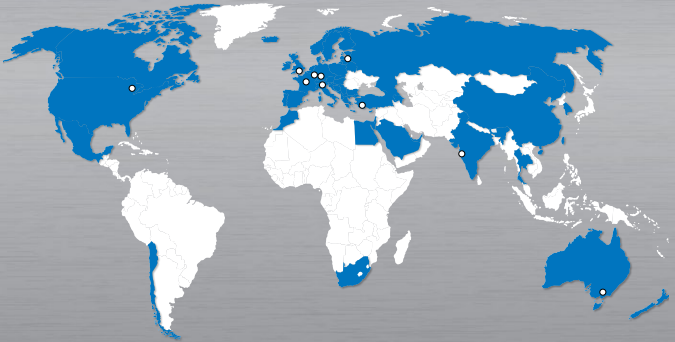

DISCOVER OUR PRODUCTS.

Our products find their way to satisfied users through an extensive network of international partners and dealers. Our partners and dealers are authorised specialists that have received extensive training in the installation of our products and in the provision of a high-quality service and appropriate advice.

To find your nearest partner or dealer, visit www.vbairsuspension.com.